

QJC398 Nooteboom 7 assige dieplader

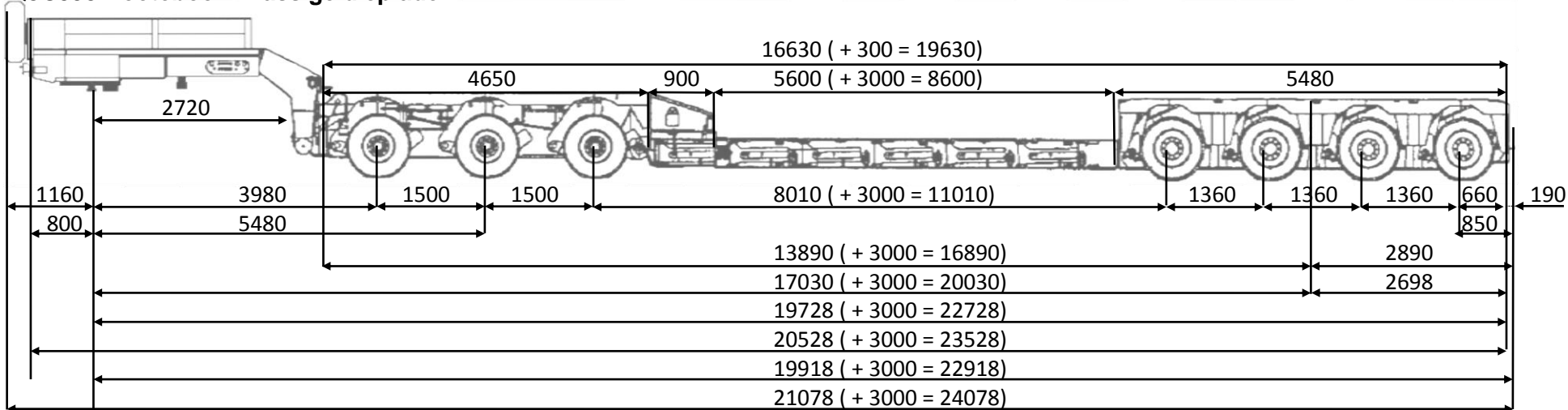

Operationeel gewicht: 9124 kg 11400/3=3800 Kg 16440/4= 4110 Kg Totaal: 36964 Kg
 Document gewicht: 6750 kg 9708/3= 3236 Kg 14992/4= 3748 Kg Totaal: 31450 Kg

Operationeel gewicht assen dolly gelift: 16984 Kg 19980/4= 4995 Kg Totaal: 36964 Kg
 Document gewicht assen dolly gelift: 13390 Kg 18060/4= 4515 Kg Totaal: 31450 Kg

Merk: Nooteboom
 Type: EURO-107-34
 Serienummer: XMREUR0070000244
 Operationeel totaal gewicht: 36964 Kg
 Document totaal gewicht: 31450 Kg

	Koppelpen	Dolly	Laadvloer	Assenstel
Rij hoogte	1285 mm	??? mm.	540 mm.	1100 mm.
Min. hoogte:	/	??? mm.	410 mm.	960 mm.
Max. hoogte:	/	??? mm.	??? mm.	1360 mm.

